

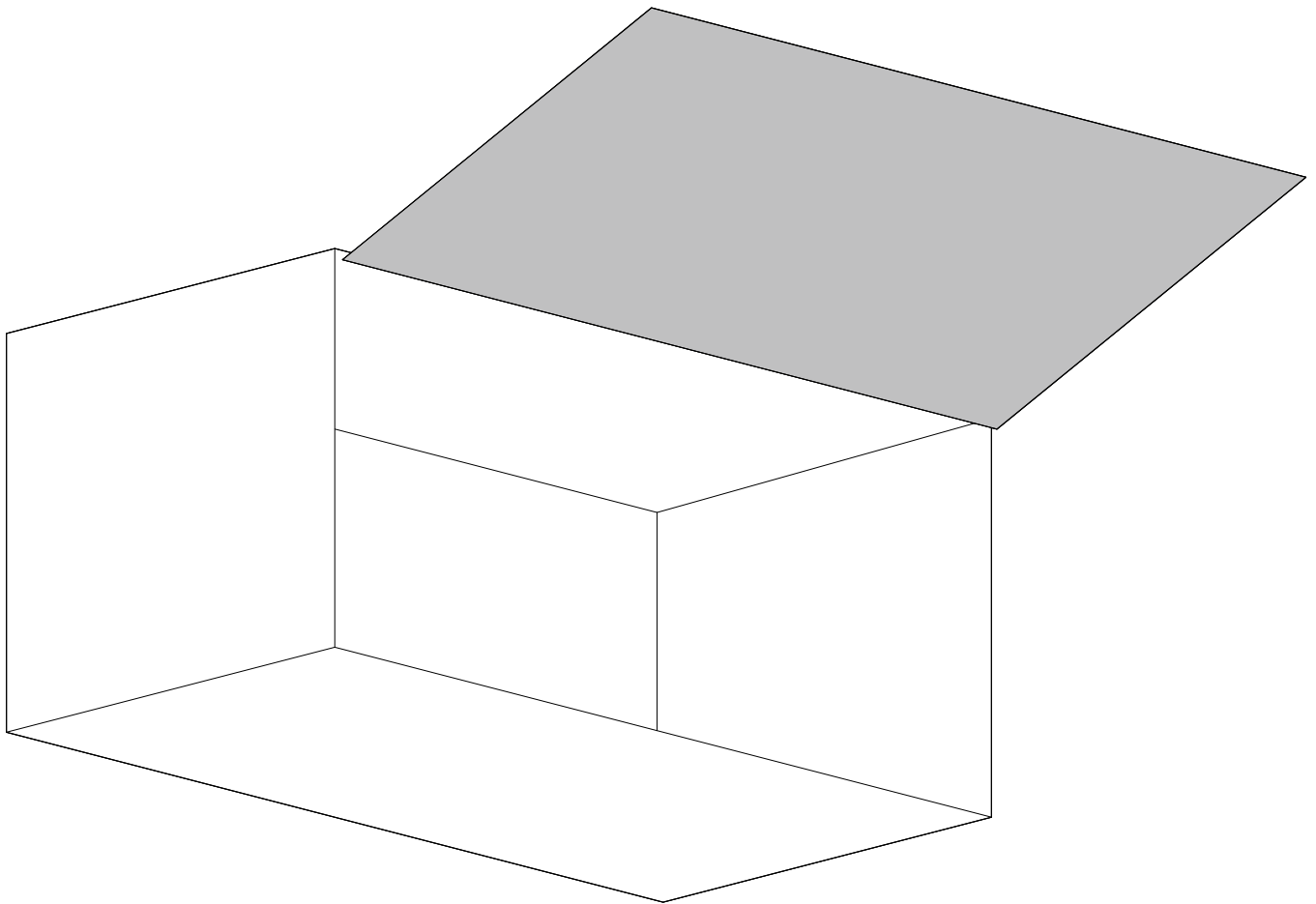

AVENTOS HK top

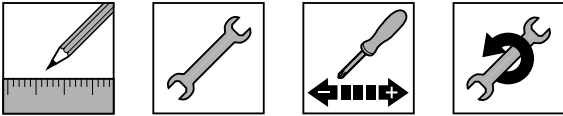

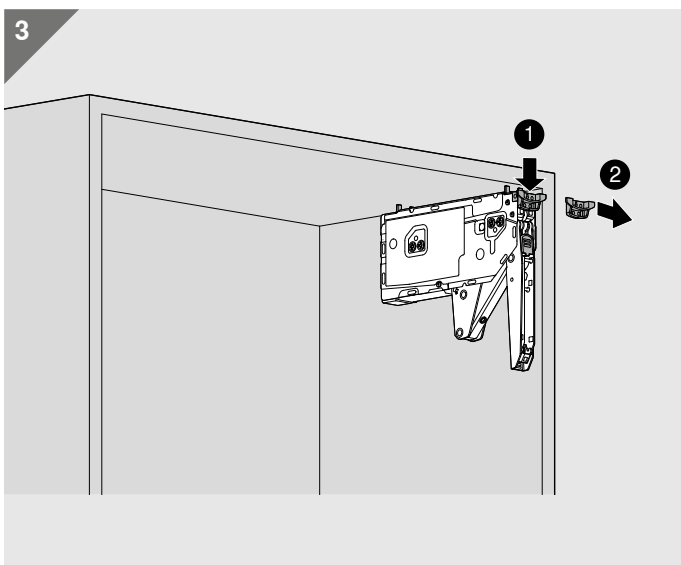

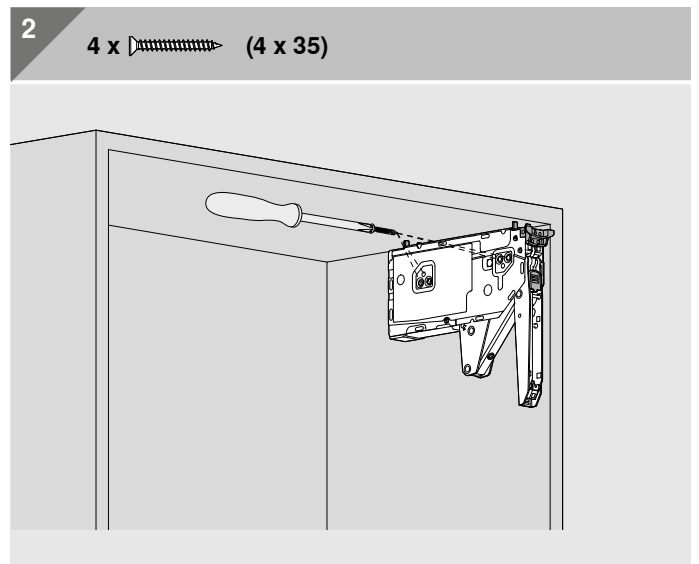
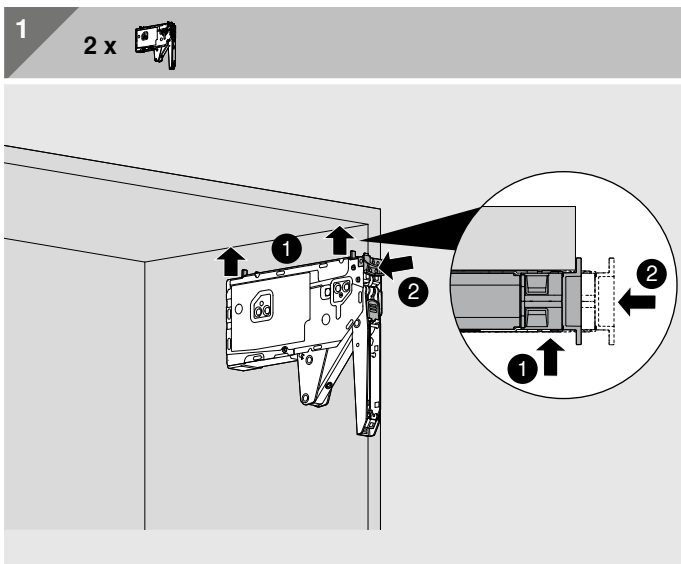
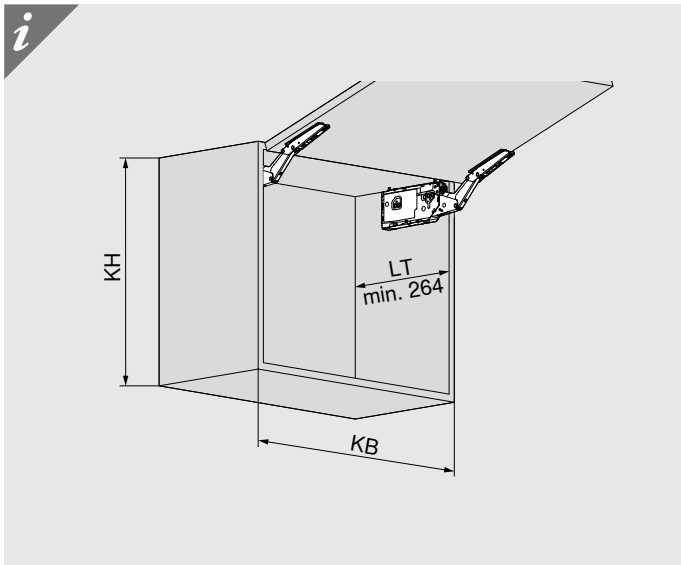
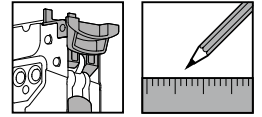
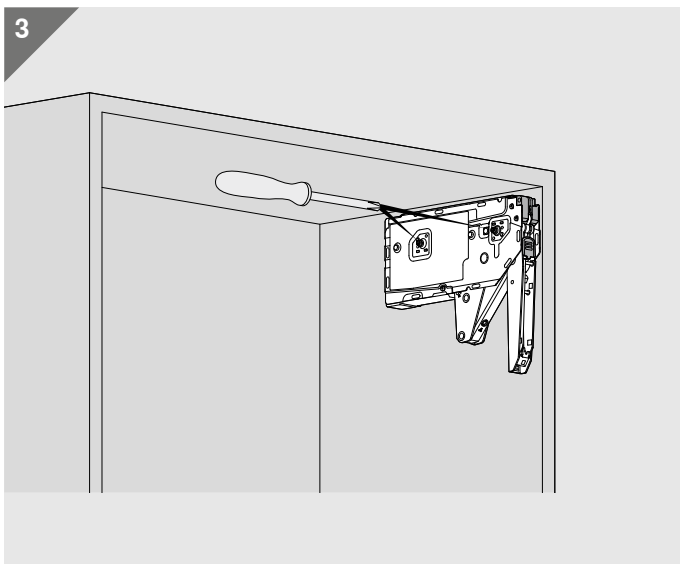
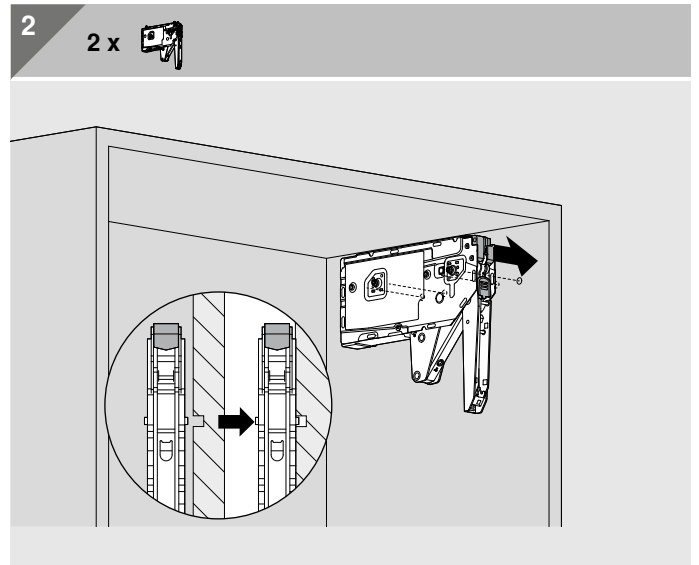
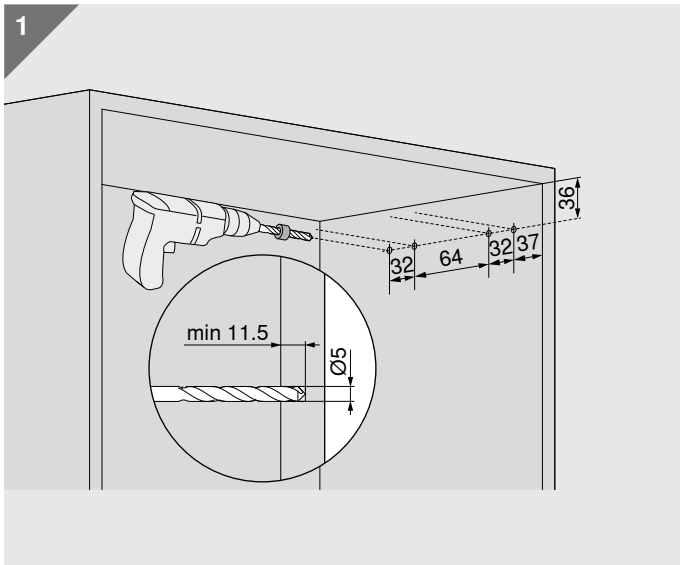
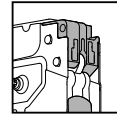

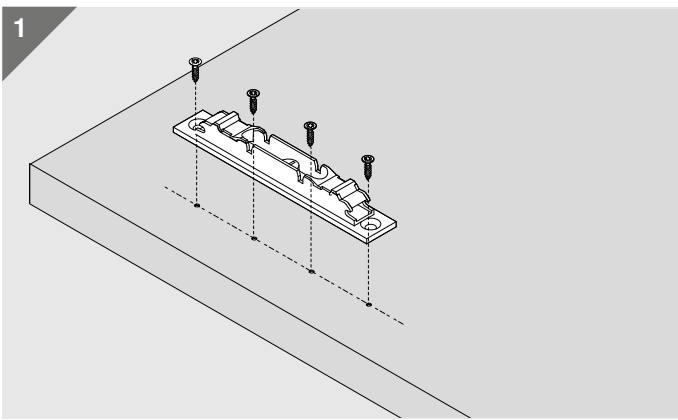
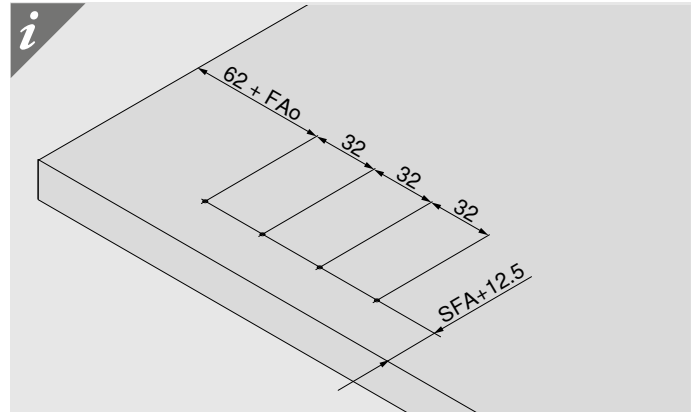
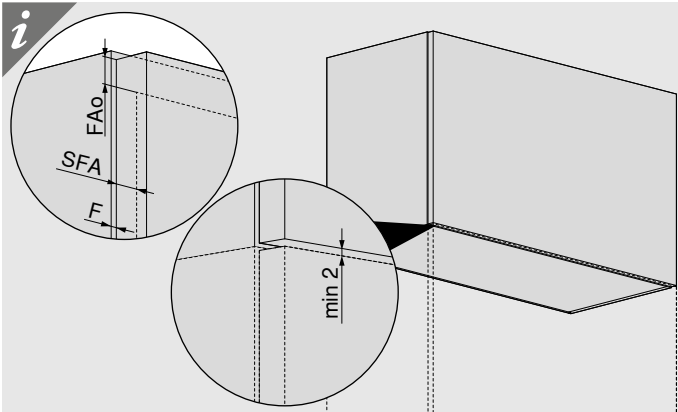



**WARNING | WARNING | AVERTISSEMENT | AVVERTENZA |
ADVERTENCIA | OSTRZEŻENIE | ВНИМАНИЕ | 警告**

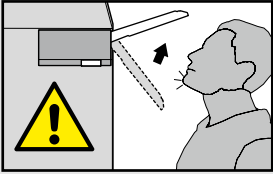

Verletzungsgefahr durch hochspringenden Hebel!
Lever could spring up and cause injury!
Risque de blessure en cas de relevage brusque du levier!
Pericolo di lesioni a causa del possibile scatto della leva verso l'alto!

Peligro de lesión por elevación de la palanca!
Niebezpieczeństwo zranienia przez gwałtownie unoszący się podnośnik!
Существует опасность получения травмы при выскакивании рычага!
アームが跳ね上がって重傷を負う可能性があります。
伸縮臂上弾会伤人!

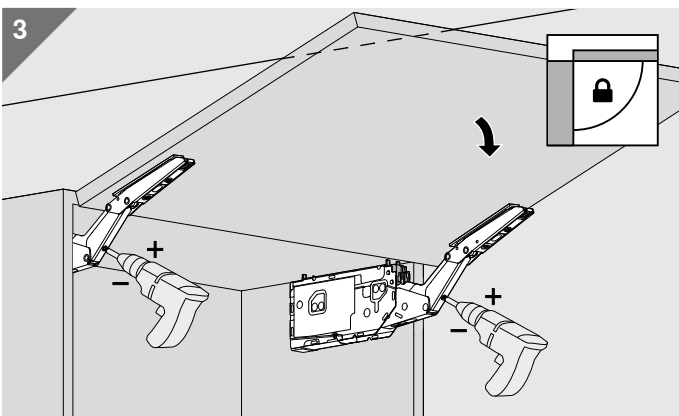
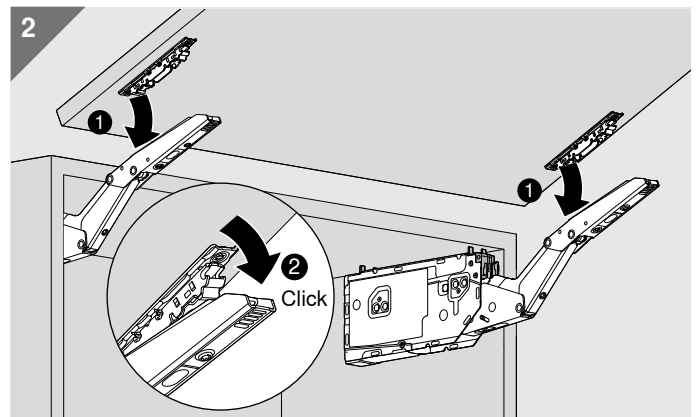
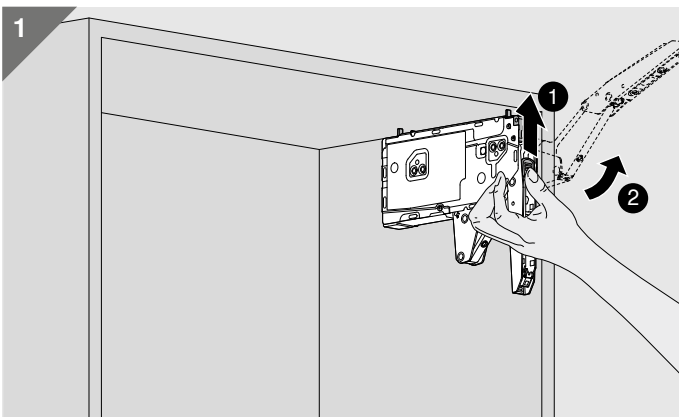
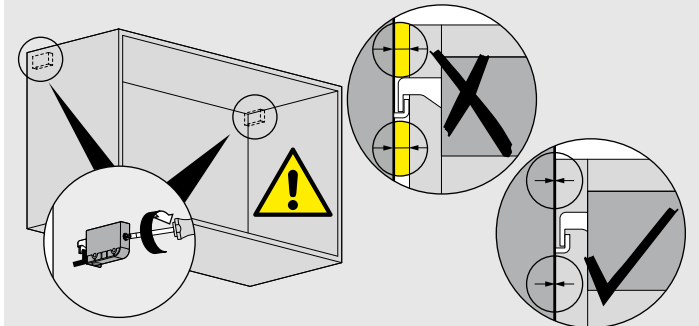

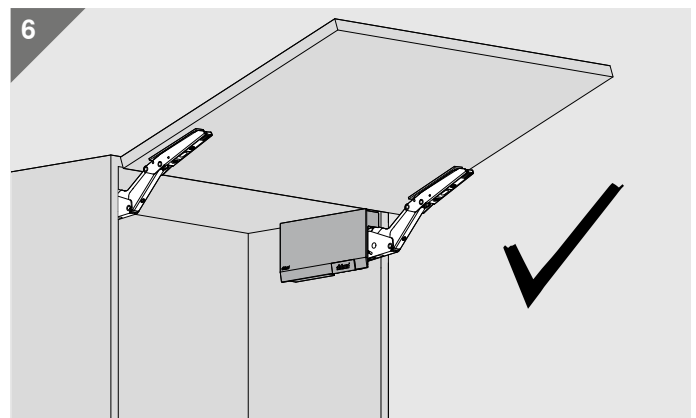
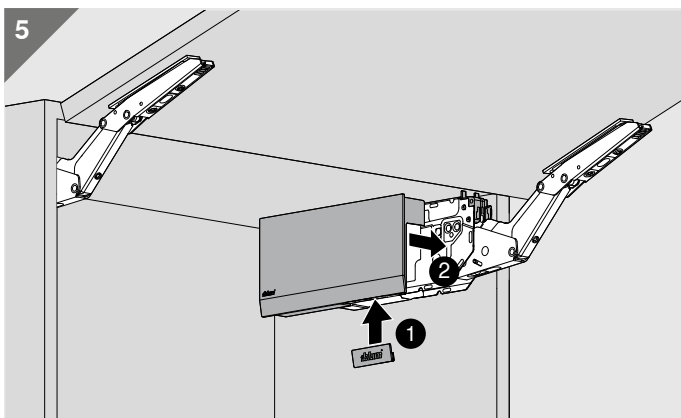
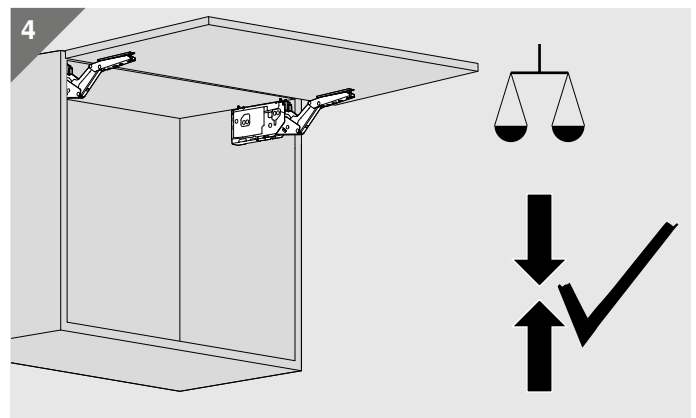
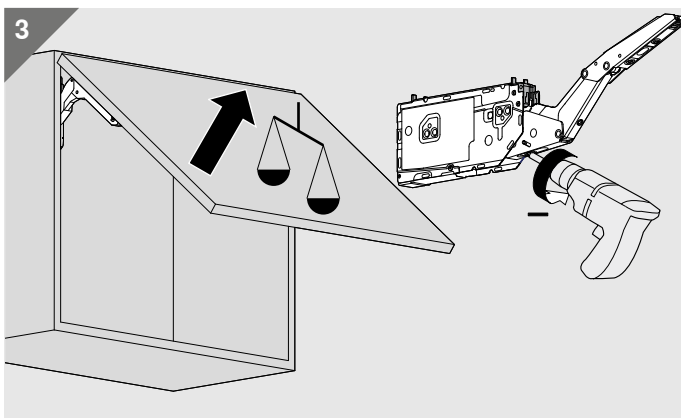
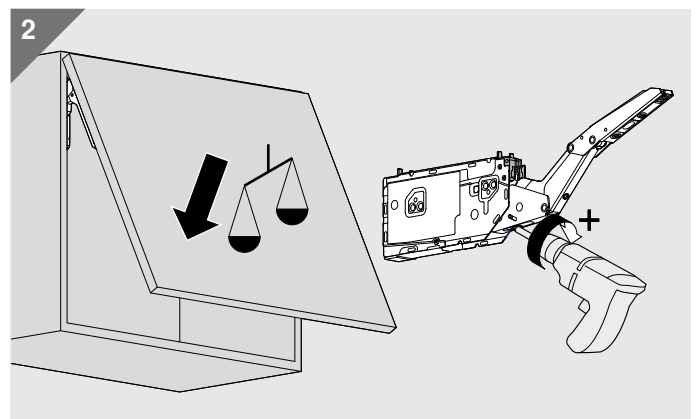
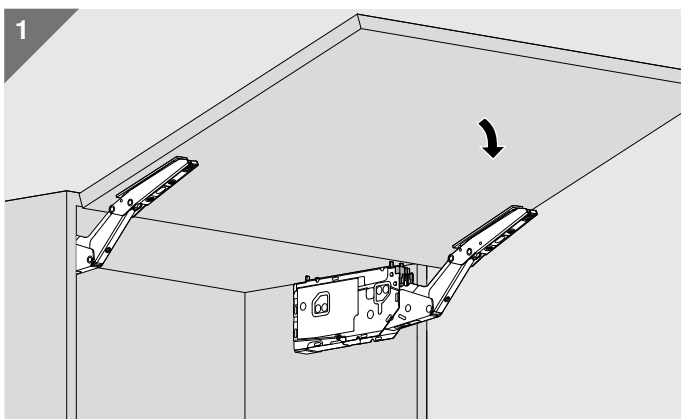
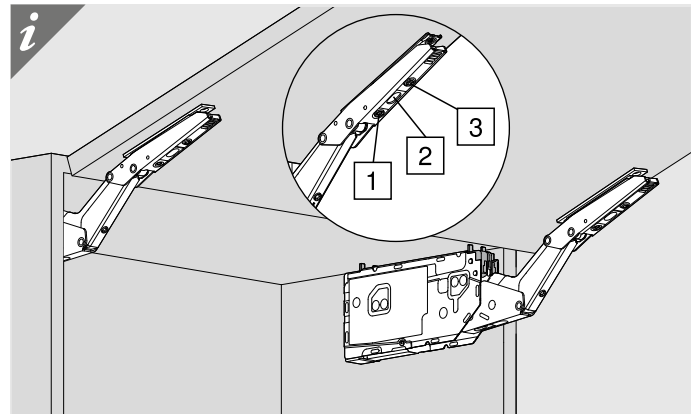
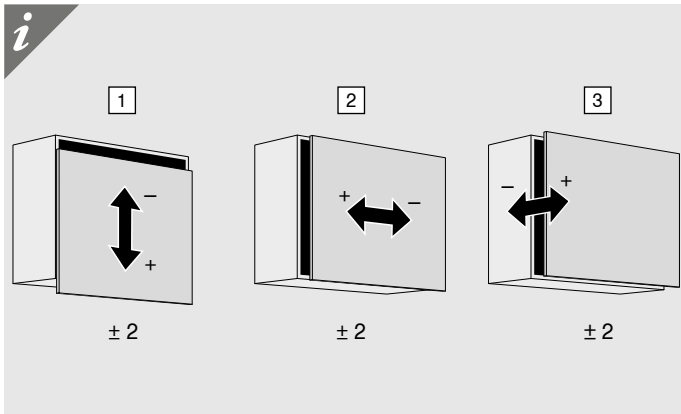



**WARNING | WARNING | AVERTISSEMENT | AVVERTENZA |
ADVERTENCIA | OSTRZEŻENIE | ВНИМАНИЕ | 警告**

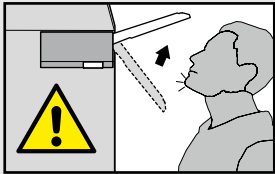

Verletzungsgefahr durch hochspringenden Hebel!
Lever could spring up and cause injury!
Risque de blessure en cas de relevage brusque du levier!
Pericolo di lesioni a causa del possibile scatto della leva verso l'alto!

Peligro de lesión por elevación de la palanca!
Niebezpieczeństwo zranienia przez gwałtownie unoszący się podnośnik!
Существует опасность получения травмы при выскакивании рычага!
アームが跳ね上がって重傷を負う可能性があります。
伸缩臂上弾会伤人!

